

Air Motor Dura-Lite Series For standard applications



The enhanced **Dura-Lite** range combine durability with affordability. Their reliable performance and application flexibility provide economical solution for a wide variety of industrial tasks.

The right torque at the right speed.

High power to weight ratio, easy installation, portability, minimum maintenance and simple controls are other features that makes Ingersoll Rand air motors an attractive option for a number of industrial applications.

Many users will find that they can substitute air motors from other manufacturers with the Ingersoll Rand **Dura-Lite** series.

The main reasons to choose a Dura-Lite Series air motor:

▪ **Variable Speed**

Controllable over a wide speed range. When an increase in load lowers the speed, the torque increases.

▪ **Explosion-Proof**

Ideal for applications in hazardous or hostile environments

▪ **Instantly Reversible**

Easy reversing using a directional control valve

▪ **Cool Running**

Cool and spark-free operation

▪ **Compact and Portable**

Air motors can work in any position and are easy to install.

▪ **Minimum Maintenance**

Simple design and construction results in low maintenance and less down time

▪ **Will Not Burn Out**

Will not overheat or sustain any other type of damage

▪ **No-shock Starts**

Accept repeated starting and stopping without limitation

▪ **Self-sealing vanes**

Vanes automatically take up their own wear

▪ **Operate in all positions**

Air motors are easy to install and can work in any position providing adequate airline lubrication

▪ **Mounting Flexibility**

Simple control methods; Torque, speed and direction can be changed using simple controls

▪ **Long Life Accessories**

Resistant to moisture, dust and heat

▪ **Output Power vs Speed**

Output which inherently adjusts to match the applied load

▪ **Torque vs Speed**

When an increase in load lowers the speed, the torque increases

▪ **Air Consumption vs Speed**

Air consumption increase only when speed or air pressure increase

▪ **Mounting flexibility**

Compact in their design the **Dura-Lite** Series motors can be delivered with Side or rear exhaust, metric flange or 2 holes flanges.



Typical Applications

- Mixing equipment
- Conveyor drives
- Beveling Machines
- Textile machinery
- Production robots
- Strapping machines
- Medical pump
- Printing machinery
- Hose reels
- Paint, Ink and Glue systems
- Punch Presses
- All applications in hazardous area...

Non Reversible Range Specifications

Model	Max Power		Speed @Max H.P	Free speed	Torque@ max power		Stall torque		Air consumption @ max Pow.		Weight	
	H.P.	K.W.			Rpm	Rpm	Ft-lbs	Nm	Ft-lbs	Nm	Scfm	L/s
2ME-55	0.28	0.21	30	65	54.94	74.5	82.96	112.5	12.92	6.1	0.50	1.1
2ME-90	0.29	0.22	45	100	35.99	48.8	56.27	76.3	12.92	6.1	0.50	1.1
2ME-225	0.29	0.22	135	275	11.73	15.9	24.19	32.8	12.92	6.1	0.50	1.1
2ME-400	0.29	0.22	225	450	7.01	9.5	13.72	18.6	12.92	6.1	0.36	0.8
2ME-600	0.31	0.23	350	700	4.72	6.4	9.07	12.3	12.92	6.1	0.36	0.8
2ME-1000	0.31	0.23	550	1100	3.02	4.1	5.68	7.7	12.92	6.1	0.36	0.8
2ME-2500	0.32	0.24	1500	3000	1.11	1.5	2.29	3.1	12.92	6.1	0.23	0.5
2ME-4000	0.32	0.24	2250	4500	0.81	1.1	1.40	1.9	12.92	6.1	0.23	0.5
202ME-50	0.38	0.28	25	55	87.91	119.2	130.9	177.5	18.01	8.5	0.59	1.3
202ME-80	0.39	0.29	35	90	56.93	77.2	88.94	120.6	18.01	8.5	0.59	1.3
202ME-200	0.42	0.31	110	225	19.69	26.7	37.98	51.5	18.01	8.5	0.59	1.3
202ME-350	0.42	0.31	200	400	10.84	14.7	22.49	30.5	18.01	8.5	0.45	1.0
202ME-550	0.42	0.31	300	600	7.45	10.1	14.53	19.7	18.01	8.5	0.45	1.0
202ME-850	0.43	0.32	500	1000	4.50	6.1	9.51	12.9	18.01	8.5	0.45	1.0
202ME-2250	0.43	0.32	1350	2700	1.70	2.3	3.47	4.7	18.01	8.5	0.32	0.7
202ME-3500	0.44	0.33	2100	4200	1.11	1.5	2.29	3.1	18.01	8.5	0.32	0.7
3ME-250	0.83	0.62	135	240	32.37	43.9	61.95	84	30.93	14.6	0.82	1.8
3ME-450	0.84	0.63	250	450	17.92	24.3	35.99	48.8	30.93	14.6	0.82	1.8
3ME-800	0.86	0.64	475	950	9.51	12.9	16.96	23	30.93	14.6	0.82	1.8

Reversible Range Specifications

Model	Max Power		Speed @Max H.P	Free speed	Torque@ max power		Stall torque		Air consumption @ max Pow.		Weight	
	H.P.	K.W.			Rpm	Rpm	Ft-lbs	Nm	Ft-lbs	Nm	scfm	L/s
22ME-360	0.25	0.19	185	335	13.42	9.9	20.20	14.9	12.08	5.7	0.50	1.1
22ME-540	0.27	0.20	280	510	9.22	6.8	13.83	10.2	12.08	5.7	0.50	1.1
22ME-900	0.27	0.20	455	825	5.70	4.2	8.68	6.4	12.08	5.7	0.50	1.1
22ME-2250	0.28	0.21	1215	2210	2.17	1.6	3.25	2.4	12.08	5.7	0.23	0.5
22ME-3600	0.28	0.21	1940	3530	1.49	1.1	2.17	1.6	12.08	5.7	0.23	0.5
2202ME-320	0.36	0.27	140	275	24.81	18.3	36.75	27.1	16.95	8	0.45	1.0
2202ME-480	0.38	0.28	220	440	14.78	10.9	23.87	17.6	16.95	8	0.45	1.0
2202ME-750	0.38	0.28	350	700	10.17	7.5	15.32	11.3	16.95	8	0.45	1.0
2202ME-2000	0.38	0.28	955	1900	3.66	2.7	5.56	4.1	16.95	8	0.32	0.7
2202ME-3000	0.38	0.28	1525	3050	2.44	1.8	3.66	2.7	16.95	8	0.32	0.7
33ME-220	0.72	0.54	110	220	63.19	46.6	89.22	65.8	38.98	18.4	0.82	1.8
33ME-405	0.74	0.55	210	425	33.62	24.8	48.95	36.1	38.98	18.4	0.82	1.8
33ME-720	0.75	0.56	370	750	19.25	14.2	26.98	19.9	38.98	18.4	0.82	1.8

Performances figure are at 90 psig 6.2 bar
Starting torque is approx. 75% of stall torque.

The Dura-Lite series motors have been design for

- * The temperature operating range from - 30 to +100°C
- * The operating air pressure range from 2 bars up to 7 bars

- * A simple in design and construction, they can be operated in all positions
- * Being powered with air compressed or nitrogen with 60 µ filtration

Definition

- 1. Length**
From 125 to 200 mm
- 2. Diameter**
From 42 to 51 mm
- 3. Exhaust**
Side or rear
- 4. Spindle**
Round keyed from 11 to 12.7 mm
Square
Threaded 3/8" : 1/2"

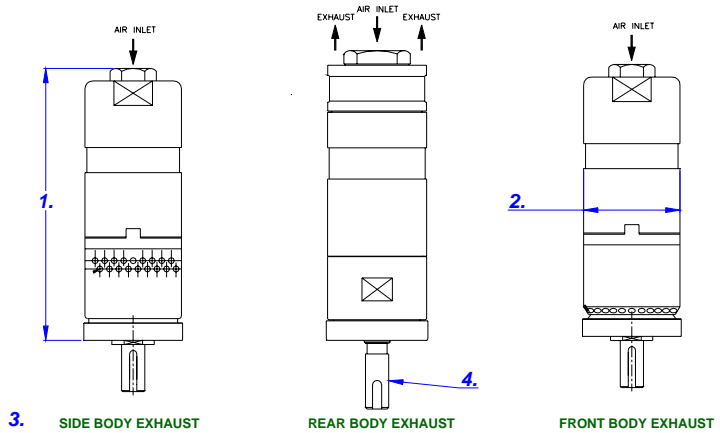

- 5. Flange**
4 holes face
2 holes lateral
4 holes lateral

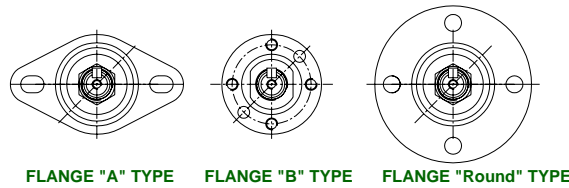

Ordering

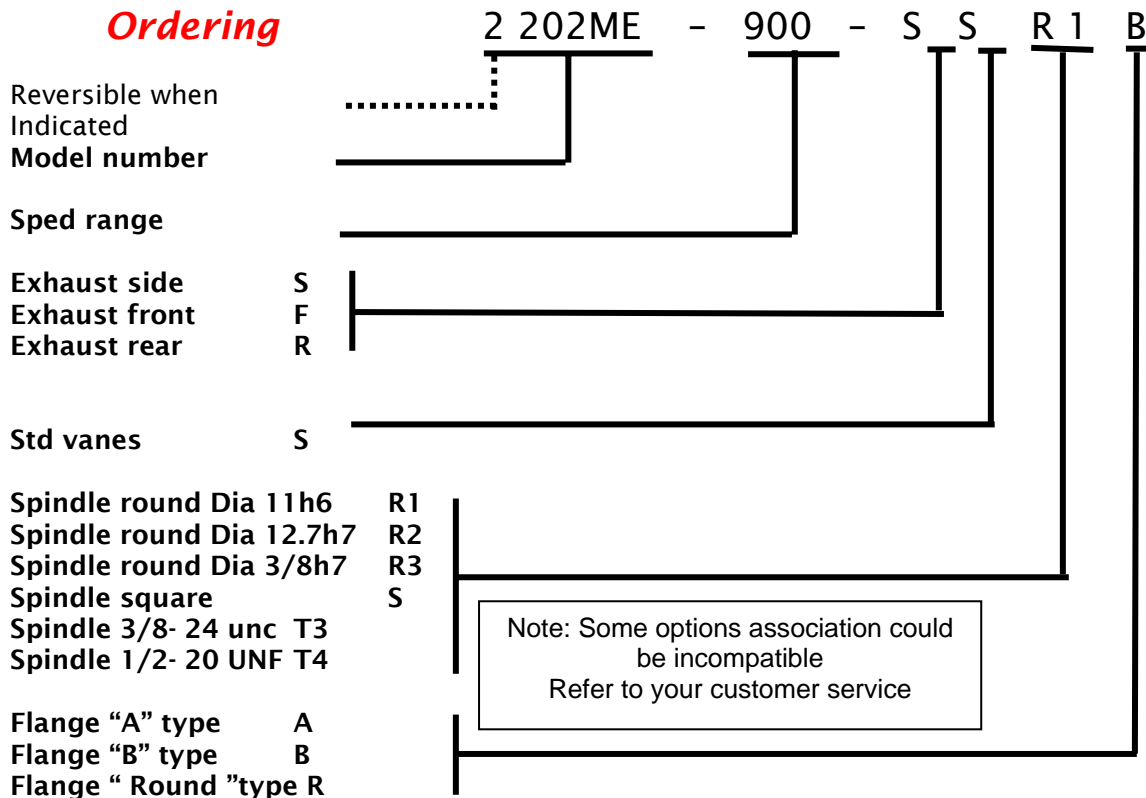

Dimensional

Models show below are with flange B, side exhaust, round shaft.

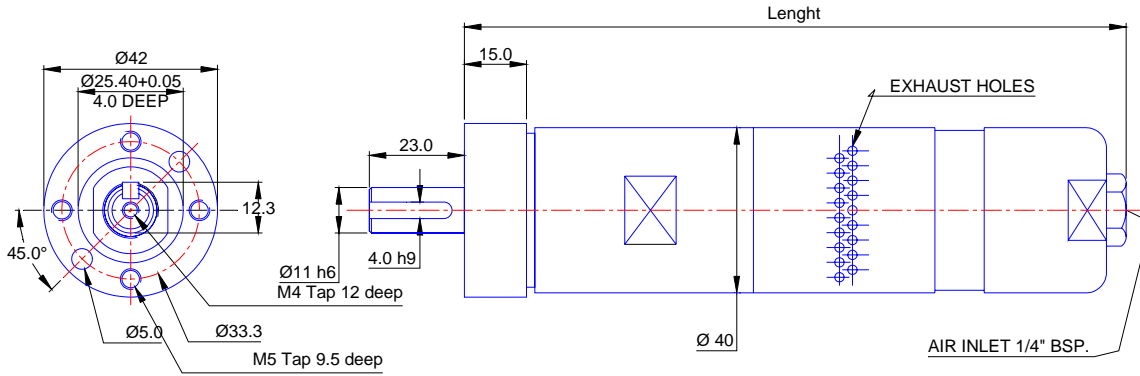

MODEL	2ME-55	2ME-90	2ME-225	2ME-400	2ME-600	2ME-1000	2ME-2500	2ME-4000
Lenght	190			160			135	
MODEL	22ME-360	22ME-540	22ME-900	2ME-2250	2ME-3600			
Lenght	150			125				

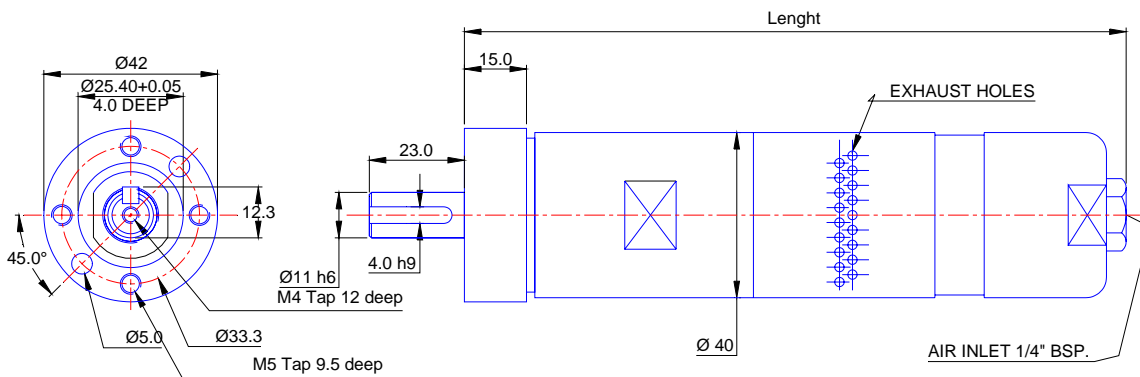

MODEL	202ME-50	202ME-80	202ME-200	202ME-350	202ME-550	202ME-850
Lenght	200			170		
MODEL	2202ME-320	2202ME-480	2202ME-750	2202ME-2000	2202ME-3200	
Lenght	160			135		

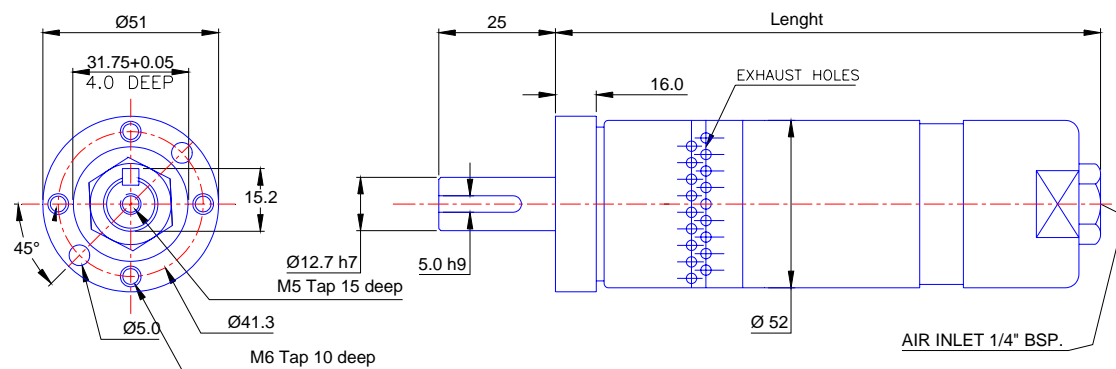

MODEL	3ME-240	3ME-450	3ME-800	MODEL	33ME-220	33ME-405	33ME-720
Lenght	200			Lenght	200		

For other model contact your customer service.

Ingersoll Rand
Industrial Technologies

TEL: 00 33 (0)1 3007 69 28
FAX: 00 33 (0)1 3007 69 69

Direct Drive and Geared Air Motor **MRV** Series

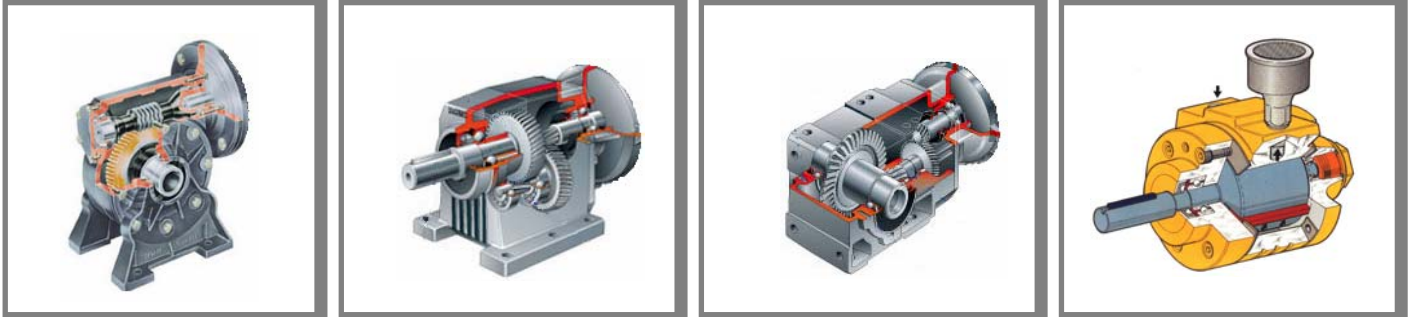

The enhanced **MRV** range of premium quality air motors has been specifically designed to cover an extremely wide range of applications at very competitive prices.

The right torque at the right speed.

Whatever is your air motor requirement, chances are we have what you are looking for.

Many users will find that they can substitute air motors from other manufacturers with the Ingersoll Rand **MRV** series

The main reasons to choose a MRV series air motor

- **Variable Speed**

Controllable over a wide speed range. When an increase in load lowers the speed, the torque increases.

- **Explosion-Proof**

Ideal for applications in hazardous or hostile environments

- **Instantly Reversible**

Easy reversing using a directional control valve.

- **Cool Running**

Cool and spark-free operation.

- **Compact and Portable**

Air motors can work in any position and are easy to install.

- **Minimum Maintenance**

Simple design and construction results in low maintenance and less down time

- **Will Not Burn Out**

Will not overheat or sustain any other type of damage.

- **No-shock Starts**

Accept repeated starting and stopping without limitation

- **Self-sealing vanes**

Vanes automatically take up their own wear

- **Operate in all positions**

Air motors are easy to install and can work in any position providing adequate airline lubrication

- **Mounting Flexibility**

Simple control methods; Torque, speed and direction can be changed using simple controls

- **Long Life Accessories**

Resistant to moisture, dust and heat

- **Output Power vs Speed**

Output which inherently adjusts to match the applied load

- **Torque vs Speed**

When an increase in load lowers the speed, the torque increases

- **Air Consumption vs Speed**

Air consumption increase only when speed or air pressure increase

- **Mounting flexibility**

Most of the **MRV** series motors size can be delivered with **Foot, Hub, Face, Nema-C or metric flange (B5, B14)**, or also with spur, 90°, or worm gear box.

Typical Applications

- Mixing Equipment
- Conveyor Drives
- Bevelling Machines
- Drills
- Production Robots
- Silos
- Pump Drives
- Hoist & Winches
- Hose Reels
- Turntables
- Actuators
- Paint, Ink and Glue Systems
- Presses
- All applications in hazardous area...

Direct Drive Range Specifications

Model	Max Power		Speed @Max H.P	Free speed	Starting torque		Stall torque		Air consumption @ max Pow.		Weight	
	H.P	K.W			Rpm	Rpm	Ft-lbs	Nm	Ft-lbs	Nm	scfm	L/s
MRV003	0,33	0,25	7600	15200	0,29	0,39	0,38	0,52	17	8,3	1-1/2	0,9
MRV005	0,42	0,52	6000	10000	0,45	0,61	0,6	0,81	42	20	2-1/2	0,95
MRV009	0,9	0,67	3000	7900	1,7	2,3	2,3	3,1	48	23,3	6	2,7
MRV015	1,47	1,1	3000	7900	2,6	3,53	4,1	5,6	67	31,6	8-1/4	2,4
MRV040	3,6	2,7	3000	7900	5,3	7,19	8,7	11,8	120	56,6	16-1/4	7,4
MRV050	4,8	3,6	2500	7000	10	13,56	14	19	152	71,6	22-1/2	10,2

Performances figure are at 90 psig 6.2 bar

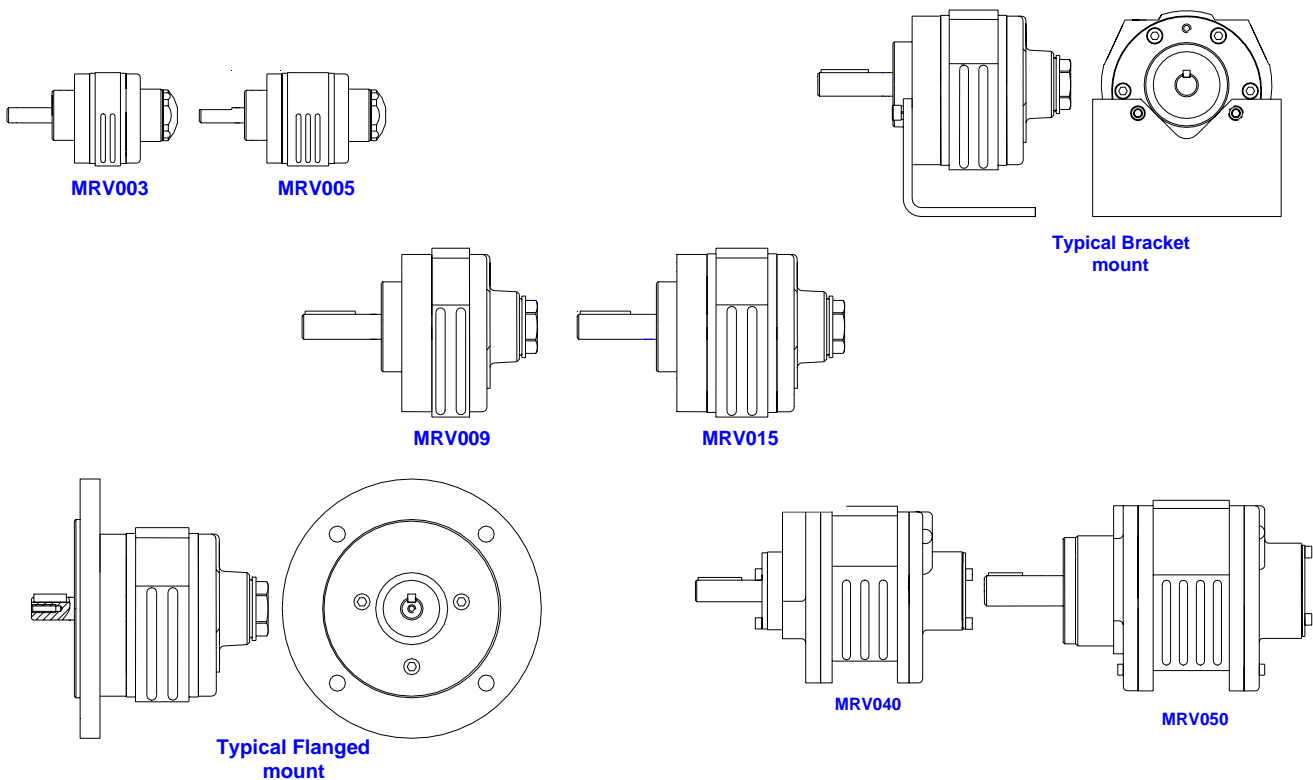

Flange mount available: B5d71, B14d7, Nema 56C, Nema 145c

The **MRV** series direct drive motors have been designed for:

- the temperature operating range from -30 to +80°C
- the operating air pressure range from 2 bars up to 7 bars
- a simple in design and construction, they can be operated in all positions
- being powered with dry air compressed or nitrogen with 60 µ filtration for special Lube Free application (except for 050 size)

Geared Drive Range Specifications

Model	Power HP		Reduction ratio		Speed @ Max HP Rpm		Starting torque		Stall torque		Weight Kg	
	from	to	from	to	from	to	from	to	from	to	from	to
design												
spur gears	0.9	4.8	3	102	28	1100	4.6	1407	5.4	1514	8.5	55
helical bevel gears	0.9	4.8	5	100	30	610	11	1349	13	1890	12.5	74
worm gears	0.9	4.8	7	100	29	610	9.9	311	9.9	635	13.5	25

Performances figure are at 90 psig 6.2 bar Gear box can be supply with flange mount design as well with base design.



Spur Gears
"C" Model

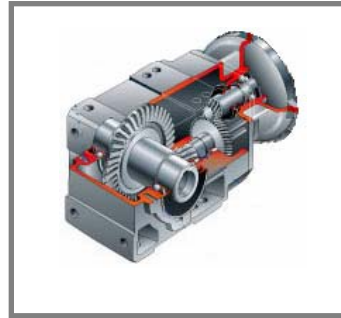

Helical Bevel Gears
"A" Model



Worm Gears
"W" Model

More than 200 models

All the **MRV** series air motors are delivered with Muffler

Operational Informations

Air pressure

When selecting air motors, remember that the specification listings show only one set of performance figures, at a particular pressure 6.2 bar. Air motors are designed to produce optimum performance at this pressure. Many other speeds, torques and power can be obtained from the same motor by regulating the pressure, air supply or exhaust. While they will operate at pressures below 2.5 bar, their performance may not be consistent. They can also be operated above 7 bar, but often at the expense of increased maintenance. A good rule to follow is to size an air motor based on approximately 70% of the lowest available air pressure. This will allow additional power for starting and possible overloading.

Desired operating speed

The desired operating speed, not the free and unloaded speed should be considered when selecting air motors. The performance curves indicate the maximum speeds at which the motor should be operated.

Required torque

Equally important as the speed at which an air motor is to be run is the required torque. The combination of the two factors speed and torque determine the power of the desired motor. Care should be taken to differentiate between stall (maximum) and running torques when selecting air motors.

Speed and torque

Starting torques are approximately 75% of stall torques. Operating or running torques at any speed can be approximated from motor performance curves or calculated using the formula:

Torque (Nm) = Power Kilowatts x 9550 / speed (revolutions per minute)

Air system and supply

Once an air motor has been selected, it is important to insure that the desired air pressure is available at the motor, while the motor is operating. A pressure reading at the compressor does not mean that the same pressure will be available to an operating air motor, because of possible restrictions and friction losses in the air system. Exhaust restrictions can also affect air motor operation, and are often the cause of performance problems.

Replacing electric motors with air motors

Electric motors, with the exception of series wound direct current motors, have entirely different performance characteristics than air motors. Therefore, their torque and speed curves will not match. Many electric motors are oversized to allow for overloading and lower power air motors can be used as replacements.



Direct drive air motor performance curve

MRV040 Serie Torque Curves

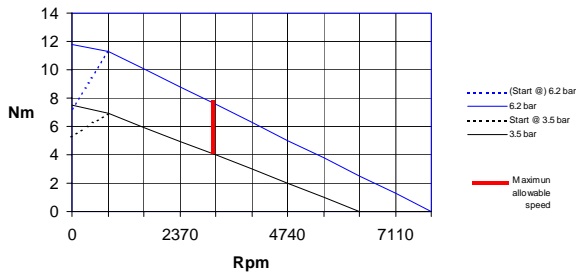

MRV040 Serie Power Curves

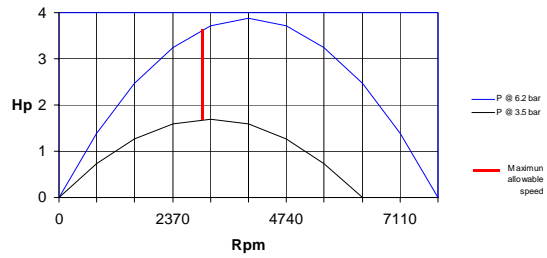

MRV050 Serie Torque Curves

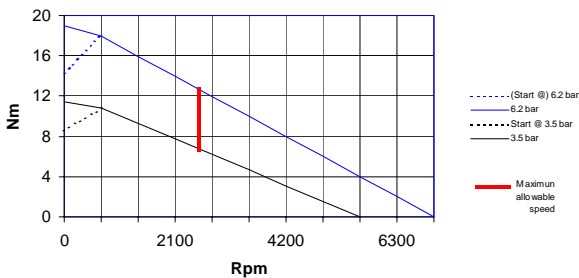

MRV050 Serie Power Curves

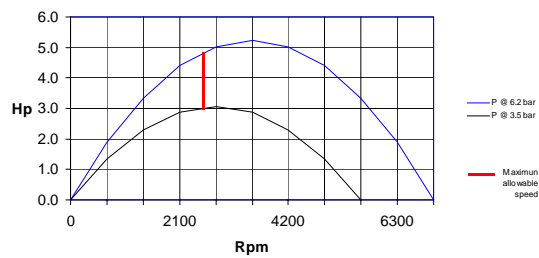

MRV003 Serie Torque Curves

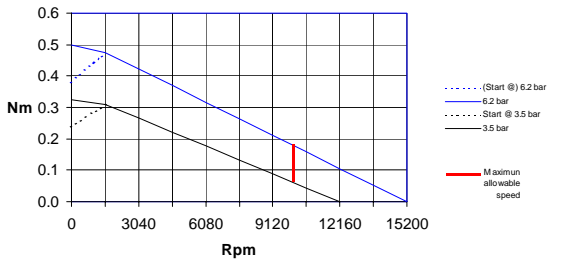

MRV003 Serie Power Curves

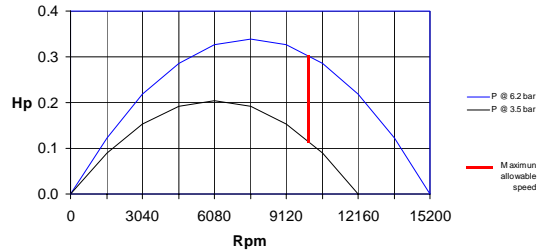

MRV009 Serie Torque Curves

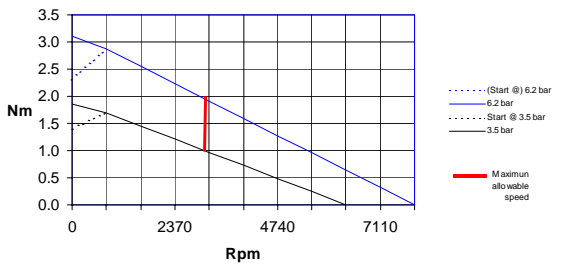

MRV009 Serie Power Curves

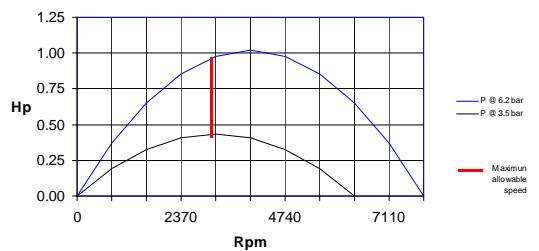

MRV015 Serie Torque Curves

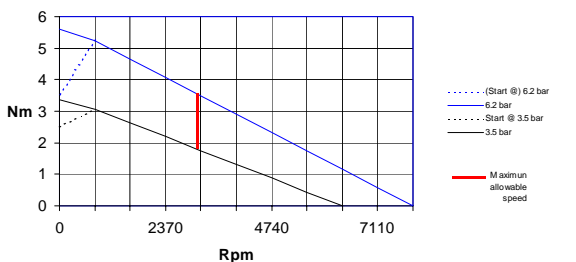

MRV015 Serie Power Curves

